

Plug and Play Solutions

NEW- All in One Whispering Window

Feonic's Whispering Window has been independently tested to deliver increased sales of up to 50% when compared to non sounding windows. The NEW boxed Whispering Window all in one solution is designed for DIY smaller retailers who are keen to attract attention to their store. The kit includes 2 x WW audio drives, a racked mounted amplifier with built in MP3 player and simple installation instructions to get you up and running in no time. A user manual also explains how to get the best out of the Whispering Window retail promotion solution.

The WW audio drives transform the entire store window into a speaker, this can be used for short audio advertisements, audio branding, in store radio, in store TV broadcasts, the possibilities are endless.

As the sound is evenly distributed throughout the windows surface, you won't have to crank up the audio to annoying levels - customers will be able to hear your messages while still being able to carry on a conversation and have a pleasant shopping experience.

Key benefits

Feonic's New WW audio drives can be attached to a store window by the very strong double sided adhesive pad. The audio drives can be left in place for years, or just for a few weeks. They are simple to install and de-install.

As sound is created both sides of the surface, the audio drives are mounted on the inside of the store, so the devices cannot be tampered with. The audio drives can be attached behind the in window vinyl graphics making them discreet and unobtrusive in your window display.

The built in MP3 player allows you to play your music from a memory card or USB stick or even your phone via Bluetooth or headphone output. You can also use the kit with a microphone for live events. The compact design allows for easy integration into any window scheme.



As used by:

blommingdales

THE WHITE COMPANY
LONDON

Harrods

SAMSUNG

CHANEL

BOSS
HUGO BOSS



John Lewis



Charlotte Tilbury

M&S
EST. 1884

★ macy's

Levi's

SONY

TOPSHOP

vodafone

NEW- Interactive Windows

Make your window interactive with touch sensitive areas,

Blah blah blah

Typical applications

- Sales Promotions
- Product Launches
- Events
- Seasonal Entertainment
- Shopping via mobile phone
- Selling using Soundbites



Plug and Play Solutions

Technical Specification



WW Drive

Impedance:	4 Ohms
Integrated Circuitry:	Overload circuit protection
Operating temperature range:	-20°C to +80°C (-68°F to 176°F)
Storage temperature range:	-20°C to +100°C (-68°F to 212°F)
Frequency Response:	120Hz-20kHz
Dimensions:	57mm (W) x 141mm (L) x 56mm (H)
Mounting method:	3M VHB adhesive tape or optional mounting plate with screw holes
Connection to amplifier:	Binding posts

Amplifier with MP3 Player

Impedance:	4 Ohms
Amplifier Power:	70W x 2
Frequency Response:	20Hz-20kHz
Connectors (each channel):	Output - Binding post
Dimensions:	57mm (W) x 141mm (L) x 56mm (H)
Audio input	MP3 player/ USB/ Bluetooth/ Mic/ Line
Tone controls	Volume, Bass & Treble
Dimensions:	500mm (W) x 245mm (L) x 65mm (H)

BOX CONTENT	2 x WW audio drive, 70W Stereo Amplifier with MP3 player, 2 x 5m speaker cable and user manual
--------------------	--

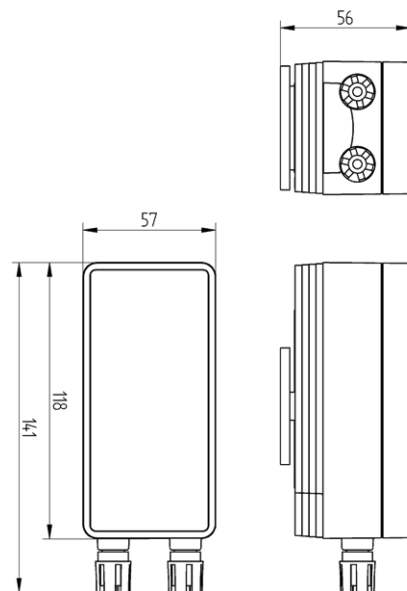

Product dimensions

